

Isolated Barrier

GS8558-EX

GYB15.1559



Please read the instruction manual carefully before use the product, and please safekeeping.

Caution

- Please check whether the product type on the package accords to the ordering contract;
- Read this manual carefully before installation or using. If there is something unclear, please dial technic support hotline-400 881 0780;
- Isolated barrier should be located in the safe area;
- Supply voltage is 24VDC, 220VAC is forbidden;
- Users are not allowed to dismantle or repair the barrier otherwise it will induce malfunction.

Connections

- (1). This barrier adopts knock-down connector with screw terminals. The intrinsically safe (IS for short) terminals (blue plugs) should be connected to hazardous area devices and the non-IS ones (green plugs) to the safe area devices.
- (2). Choose for the hazardous area the blue-marked wires. Its minimum cross section area should be 0.5 mm², and minimum dielectric strength should be 500V.
- (3). The wirings in safe area and hazardous area must be separated, and both have protection bushes.
- (4). A length of 8mm bared wire is locked by the M3 bolt. See as shown below.

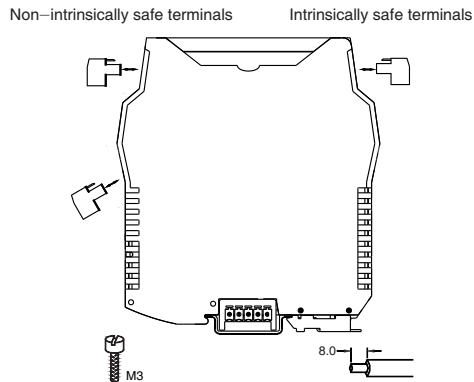

Installation

The isolated barrier should be located at safe area, according to the related requirements in IEC60079-17(EN60079-17) and IEC60079-19(EN60079-19).

GS8500-EX series isolated barrier are designed for mounting on 35mm DIN guide rail.

Installation according to the following steps:

- (1). First make the bus-powered outlet locked into the guide rail; (If no bus-powered function, omit this step);
- (2). Make the upside of the barrier locked into the guide rail;
- (3). Push the downside of the barrier in the rail.

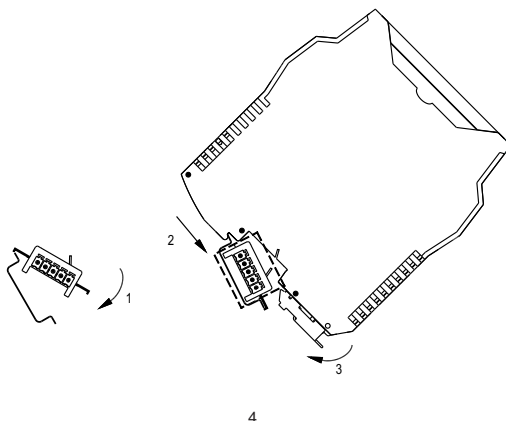

Disassembly

- (1). Insert a screwdriver (its edge length ≤ 6mm) into the downside metal lock of the barrier;
- (2). Push the screwdriver upwards, then prize the metal lock downwards;
- (3). Take the barrier out of the guide rail.

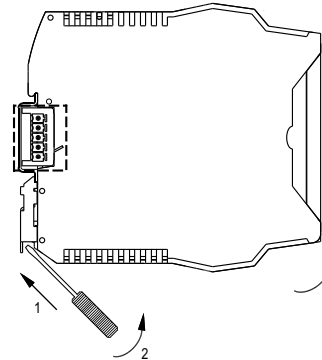

Maintenance

- (1). Before using, please check again whether the module's Ex-proof rating accords to the operation conditions, and also wiring and polarity are correct.
- (2). It is disallowable to test insulativity among the terminals with a megameter. If necessary, the wires must be cut off before testing, or the internal fuse would blow.
- (3). Every product has been test strictly before leaving factory. If users find any abnormality in the module, please contact the nearest agent or our company.
- (4). In 5 years from the delivery date, if the product works improperly during normal operation, we will repair or replace it without payment.

SHANGHAI CHENZHU INSTRUMENT CO.,LTD.

Add: Building 6, 201 Minyi Road, Caohejing Hi-Tech Park
 Songjiang New Industrial Park, Shanghai 201612, P.R. China
 Tel : +86-21-64513350 Fax : +86-21-64846984
 Email : chenzhu@chenzhu-inst.com
<http://www.chenzhu-inst.com>



Summarize

Vibration sensor input isolated barrier, voltage signal outputed by sensor in hazardous area can be 1:1 transmission to safe area, can transmit AC and DC signals. Input circuit,output circuit and power supply are each galvanically isolated.

Specification

Number of channels: 1

Supply voltage: 20~35V DC

Current consumption: ≤40mA

Safe-area output:

Signal: -10V~+10V

Load resistance: $R_L \geq 20k\Omega$

Hazardous-area input:

Signal: -10V~+10V

Impedance: 10k Ω

DC Transfer accuracy: < ±0.2%F.S.

AC Transfer accuracy: 0Hz~600Hz ±0.2%F.S.

600Hz~10kHz -1.5%~+0.2%F.S.

Phase response: Less than 10us is equals to

-0.72° 200Hz

-2° 600Hz

-3.6° 1kHz

-36° 10kHz

Voltage bandwidth: -3dB≤40kHz

Temperature drift: 0.005%/°C(-20°C~+60°C)

Power supply protection: Protect the barrier form reverse supply vltge destroy

Electromagnetic compatibility:According to GB/T 18268(IEC 61326-1)

Dielectric strength:

Between non-intrinsically safe circuits and intrinsically safe circuits≥2500VAC

Between power supply part and non-intrinsically safe part≥500VAC

Insulation resistance:

Between non-intrinsically safe part and intrinsically safe part≥100M Ω

Between power supply part and non-intrinsically safe part≥100M Ω

Weight: Approx.100g

Suitable location:

Mounting in non-hazardous area, and connected to the IS apparatus in zone 0 hazardous area.

Suitable IS apparatus:

Vibration sensor

Operation Conditions

(1). The air should not contain any medium corrupting the coat of chrome,nickel and silver.Moreover,violent quiver and impact or any cause of electromagnetic induction (such as big current or spark,etc.)must be avoided when using.

(2). Operating temperature: -20°C~+60°C

(3). Storage temperature: -40°C~+80°C

(4). Relative humidity: 10%~90%

Safety Certificates

National Supervision and Inspection Center for Explosion Protection and Safety of Instrumentation(NEPSI)

Compliance with standard: GB3836.1、GB3836.4 and GB3836.20

Ex-marking: [Ex ia Ga] IIC

maximum voltage: $U_m=250V$

Intrinsic safety parameter:(7,8 terminals)

$U_o=1.2V, I_o=0.2mA, P_o=0.06mW$

IIC : $C_o=100\mu F, L_o=100mH$

IIB : $C_o=300\mu F, L_o=300mH$

IIA : $C_o=800\mu F, L_o=800mH$

Largest external capacitance (C_o) and inductance (L_o) numerical attention when using the following requirements:

(1) For distributed inductance and capacitance e.g. as in a cable, allow the values of capacitance and inductance;

(2) For circuits containing up to 1 % inductance or up to 1% capacitance with a cable, allow the values of capacitance and inductance;

(3) For connection of the combined inductance and capacitance where both are greater than 1% of the allowed value (excluding the cable), allow up to 50% each of the values of capacitance and inductance.

Intrinsic safety explosion protection loop system

Special requirements have to be confirmed before using the intrinsically safe explosion loop system(intrinsically circuit) which connected by isolated barrier and intrinsically safe apparatus in field:

(1) The explosion level of intrinsically safe apparatus should meet the requirements of operation conditions. The apparatus should pass the explosion protection test and get the certificate by state-authorized explosion-proof product certification bodies.

(2) The intrinsic safety parameters of isolated barrier and intrinsically safe apparatus both are sure, and comply with 12.2.5 of GB 3836.15-2000.

(3)If any parameters are unclear, the system has to be confirmed by state-authorized explosion-proof product certification bodies.

Application

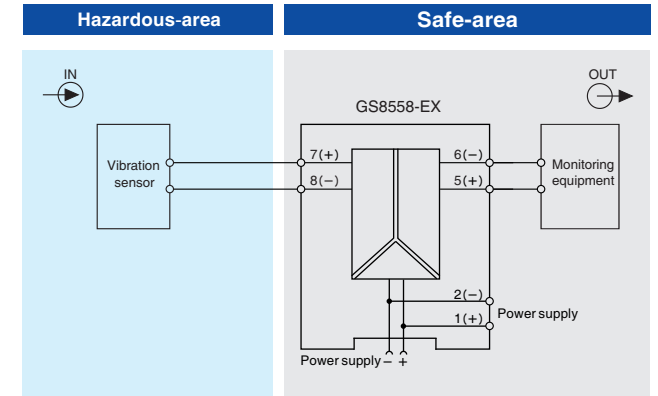

Dimensions

118.9mm×106.0mm×12.5mm

